

DL-4200 LO-PRO SLASHER

LOW PROFILE SAWBOX FOR GREAT VISIBILITY, AND EASY LOADING AND UNLOADING OF STEMS.

RELIABLE, ECONOMICAL BELT DRIVE ENSURES SMOOTH FAST CUTS IN ANY SITUATION.

CAM TYPE CHAIN ADJUSTER FOR EASY BAR & CHAIN MAINTENANCE.

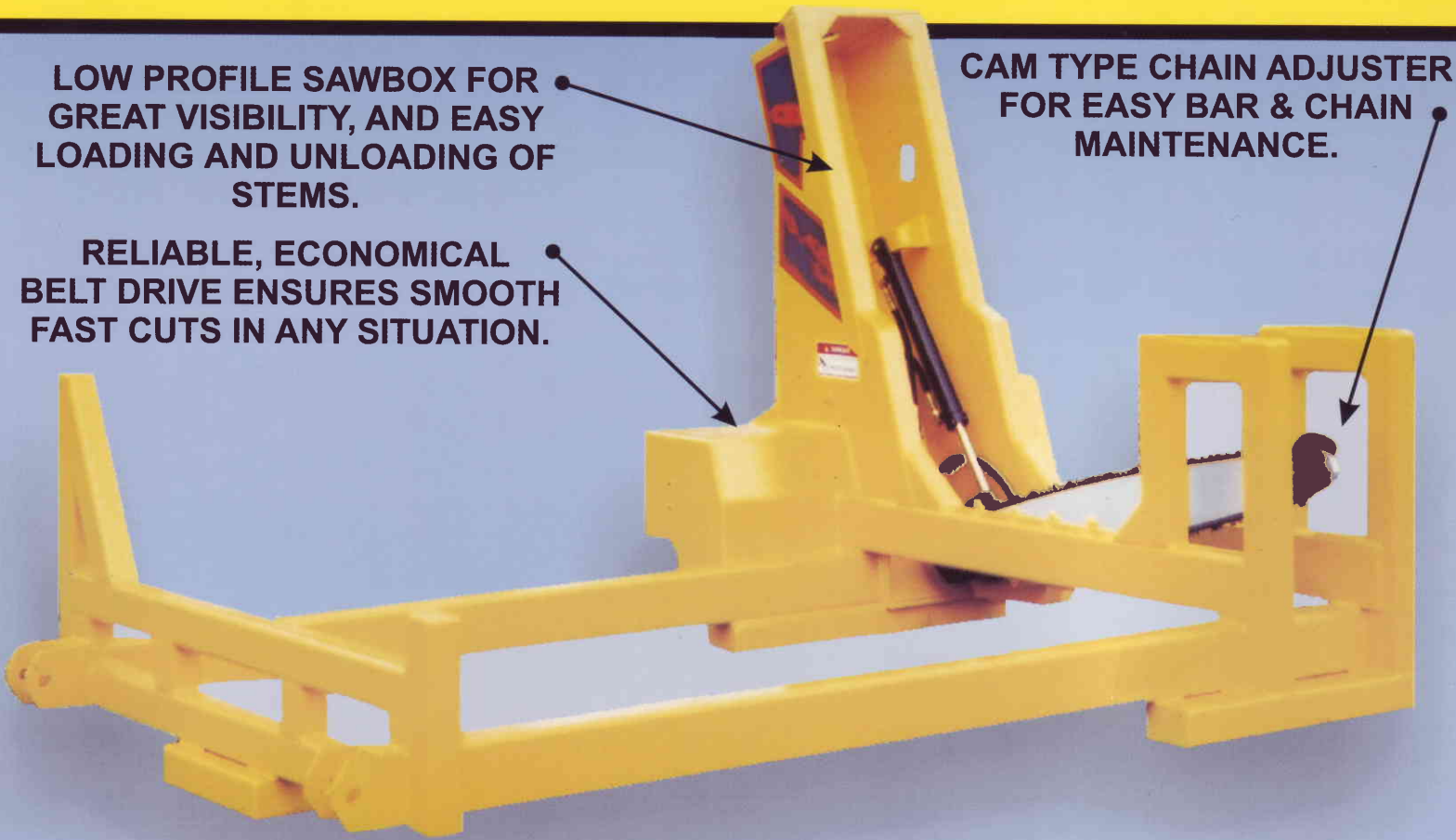

CSI MODEL DL-4200
LO-PRO-SLASHER
SHOWN WITH STANDARD 8ft CHASSIS

AMERICAN MADE



THIS LITTLE SAW CAN DO IT ALL !!

- ▶ 44" BUCK WIDTH OFFERS YOU THE CUTTING ABILITY OF A BIG SLASHER WHILE TAKING UP LESS SPACE ON YOUR LANDING.
- ▶ LOWER SAWBOX HEIGHT OFFERS BETTER VISIBILITY FOR THE LOADER OPERATOR.
- ▶ BELT DRIVE OFFERS SMOOTH FAST CUT CYCLES, AND WORKS BETTER WITH THE LOW FLOW HYDRAULIC CIRCUITS ON SOME LOADERS.



CUTTING SYSTEMS INC.

774 ZEB ROAD UNION GROVE NC 28689
TOLL FREE: 877-844-1274 FAX: 704-592-4458

EMAIL: CSI_1INC@YAHOO.COM
WEBSITE: WWW.CUTTINGSYS.COM



ALL CHASSIS BUILT WITH HEAVY WALL
HIGH ALLOY STEEL TUBE - HIGH ALLOY
STEEL GUSSETING AND PRECISION
WELDS TO GUARANTEE YEARS OF
TROUBLE FREE SERVICE

CHASSIS OPTIONS

EXTENDED FLAT CHASSIS
CUSTOMER SPECIFIC LENGTHS
AVAILABLE UPON REQUEST

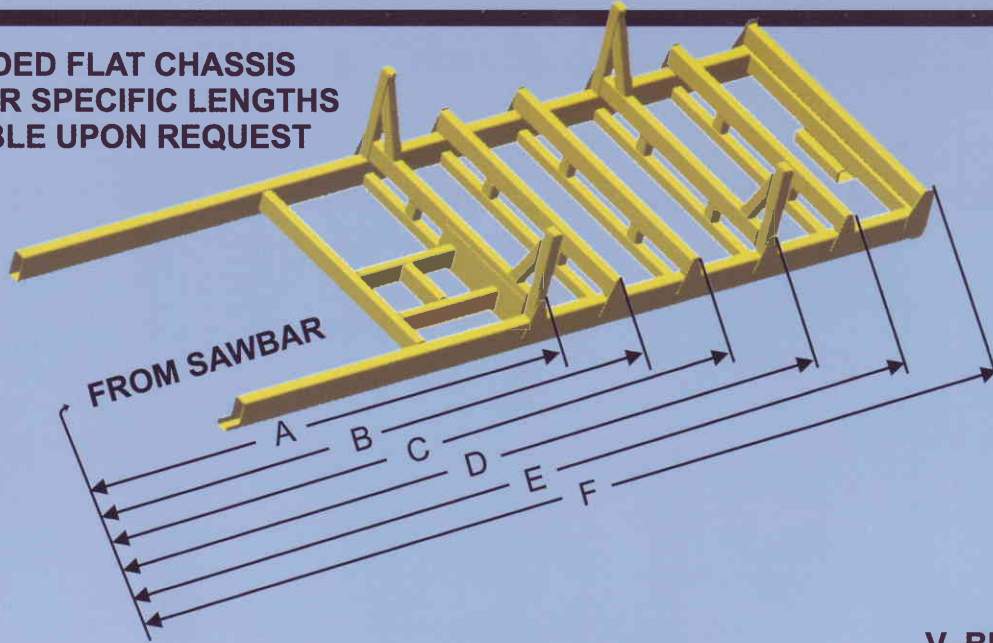

- A = 8'-6"
- B = 10'-6"
- C = 12'-6"
- D = 14'-6"
- E = 16'-6"
- F = 18'-6"

STANDARD CONFIGURATION
* FLAT CHASSIS MEASUREMENTS
ARE TO BACK SIDE OF CROSS TUBE

V-BUCK CHASSIS
CUSTOMER SPECIFIC LENGTHS / RISE
AVAILABLE UPON REQUEST

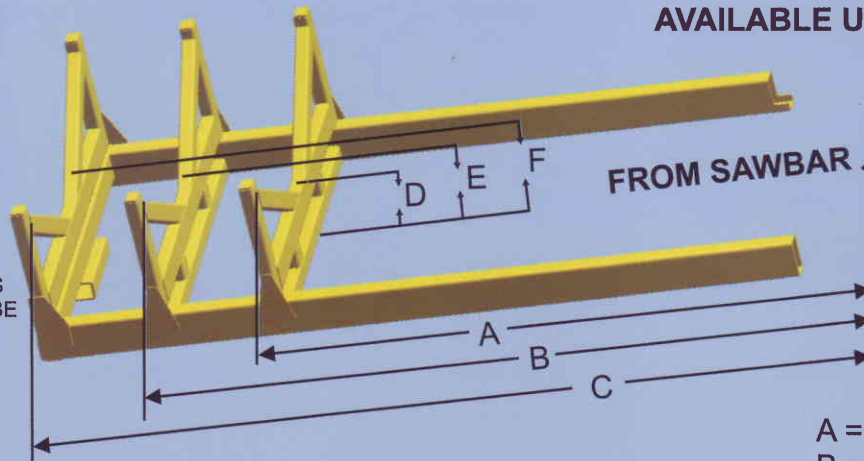

- A = 8'-6"
- B = 10'-6"
- C = 12'-6"
- D = +2" RISE
- E = +2" RISE
- F = +2" RISE

STANDARD CONFIGURATION
* V-BUCK CHASSIS MEASUREMENTS
ARE TO FRONT SIDE OF CROSS TUBE

STAIR STEP CHASSIS
CUSTOMER SPECIFIC LENGTHS / RISE
AVAILABLE UPON REQUEST

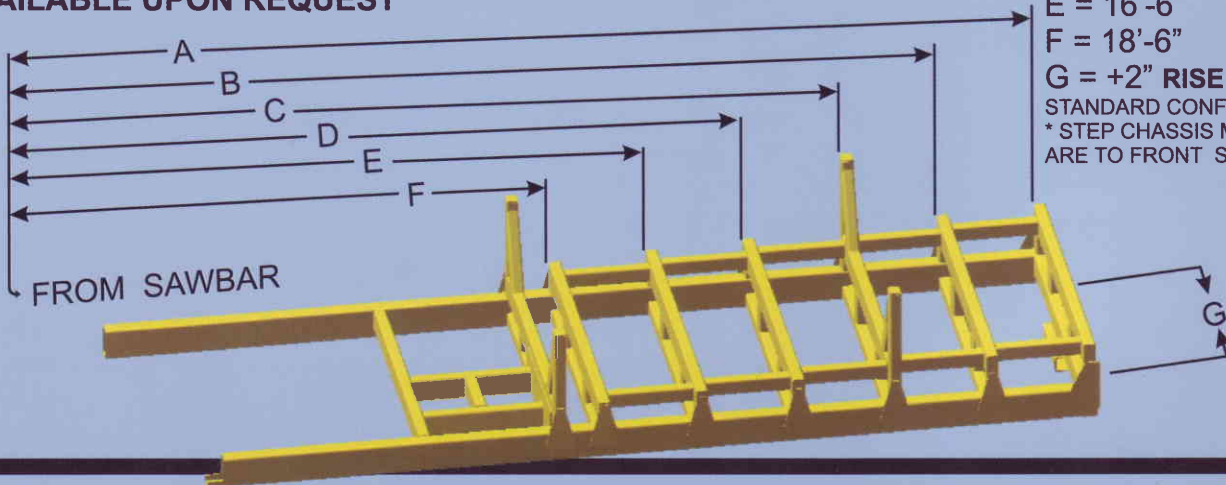

- A = 8'-6"
- B = 10'-6"
- C = 12'-6"
- D = 14'-6"
- E = 16'-6"
- F = 18'-6"

G = +2" RISE PER BUCK
STANDARD CONFIGURATION
* STEP CHASSIS MEASUREMENTS
ARE TO FRONT SIDE OF CROSS TUBE

CUSTOMIZE YOUR SAW WITH A
CHASSIS BUILT TO SUIT YOUR INDIVIDUAL NEEDS !!

OVERVIEW

**BELT DRIVE RESULTS
IN FAST CUT CYCLES IN
ANY TYPE OF WOOD**



**CSI MODEL DL-4200
LO - PRO WORKING
APPALACHIAN
HARD WOOD**

FROM WELDING



TO HYDRAULICS

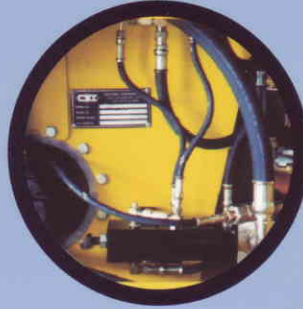

TO FINISHED PRODUCT



WE ARE SUPERIOR IN OUR FIELD



**THE DL-4200 LO-PRO
TACKLES HARDWOOD
WITH EASE THANKS TO
ITS RUGGED BUILT
CHASSIS AND EFFICIENT
HYDRAULICS**

**CSI MODEL DL-4200
LO - PRO WORKING
APPALACHIAN
HARD WOOD**

DL-4200 LO-PRO

SPECIFICATIONS

THE MODEL 4200 LO-PRO CAN BE ORDERED IN A WIDE VARIETY OF CONFIGURATIONS.

THESE INCLUDE :

REVERSIBLE CHASSIS

DETACHABLE EXTENDED CHASSIS

FLAT CHASSIS

V-BUCK CHASSIS

STEP CHASSIS

CUSTOMER SPECIFIC CHASSIS DIMENSIONS

AVAILABLE UPON REQUEST

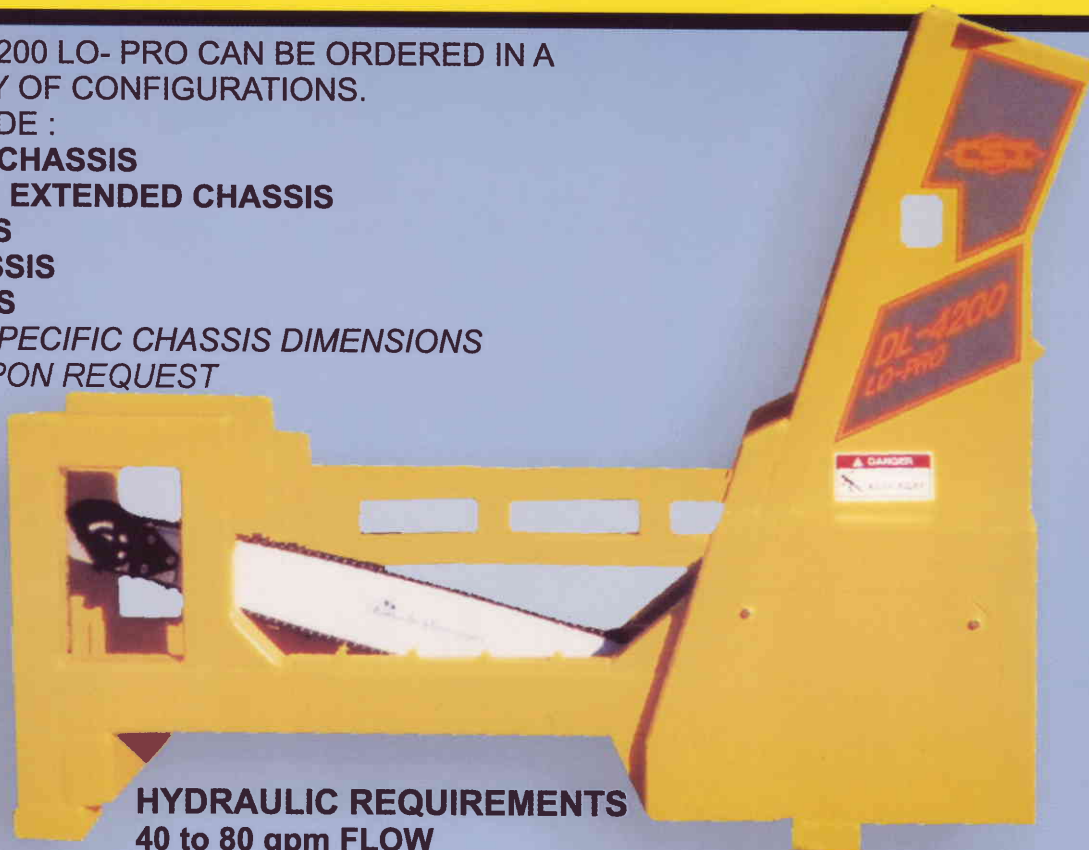

HYDRAULIC REQUIREMENTS
40 to 80 gpm FLOW
2000 to 2500 psi PRESSURE

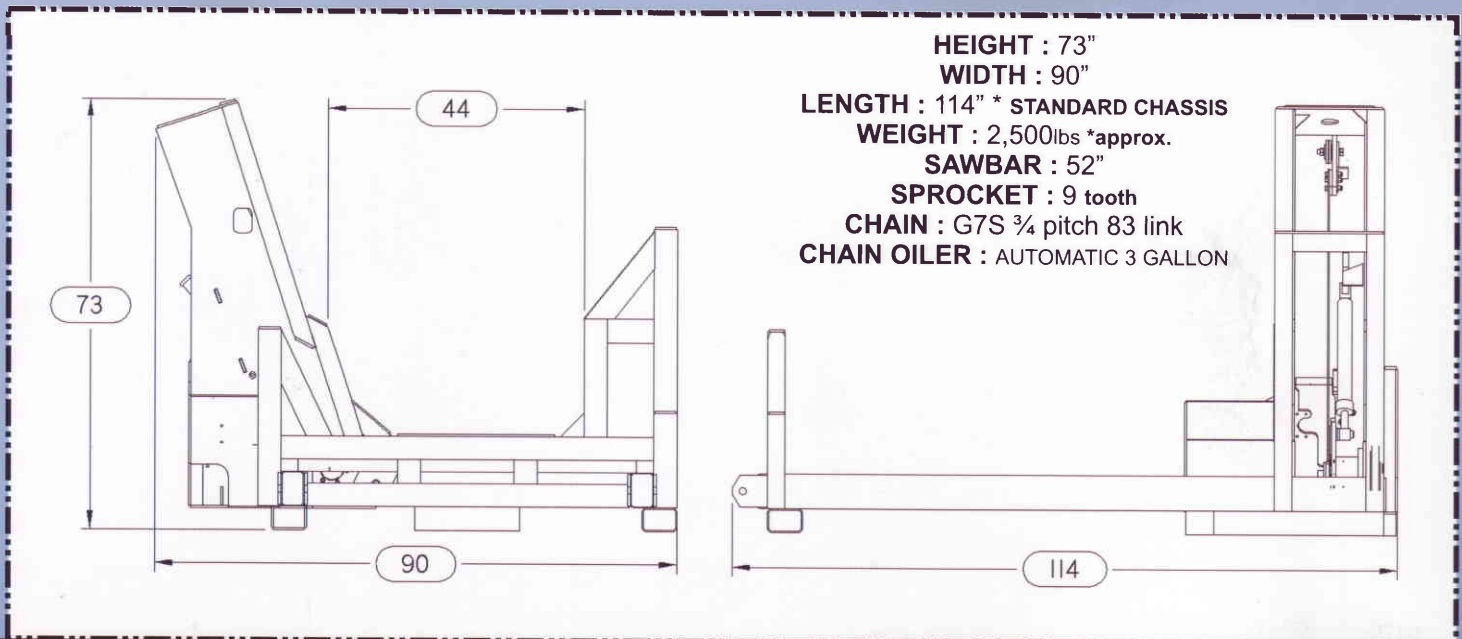

CUTTING SYSTEMS INC.

TOLL FREE: 877-844-1274 FAX: 704-592-4458

SOLD AND SERVICED BY:

